

HOSPICAB CH LONG SSH 9003

- | | | |
|---|-----|-------------------------|
| 1 | SK | Montážny návod |
| 2 | CZ | Montážní návod |
| 3 | DE | Montageanleitung |
| 4 | ENG | Assembly instructions |
| 5 | PL | Instrukcja montażu |
| 6 | RO | Instrucțiuni de montaj |
| 7 | IT | Istruzioni di montaggio |

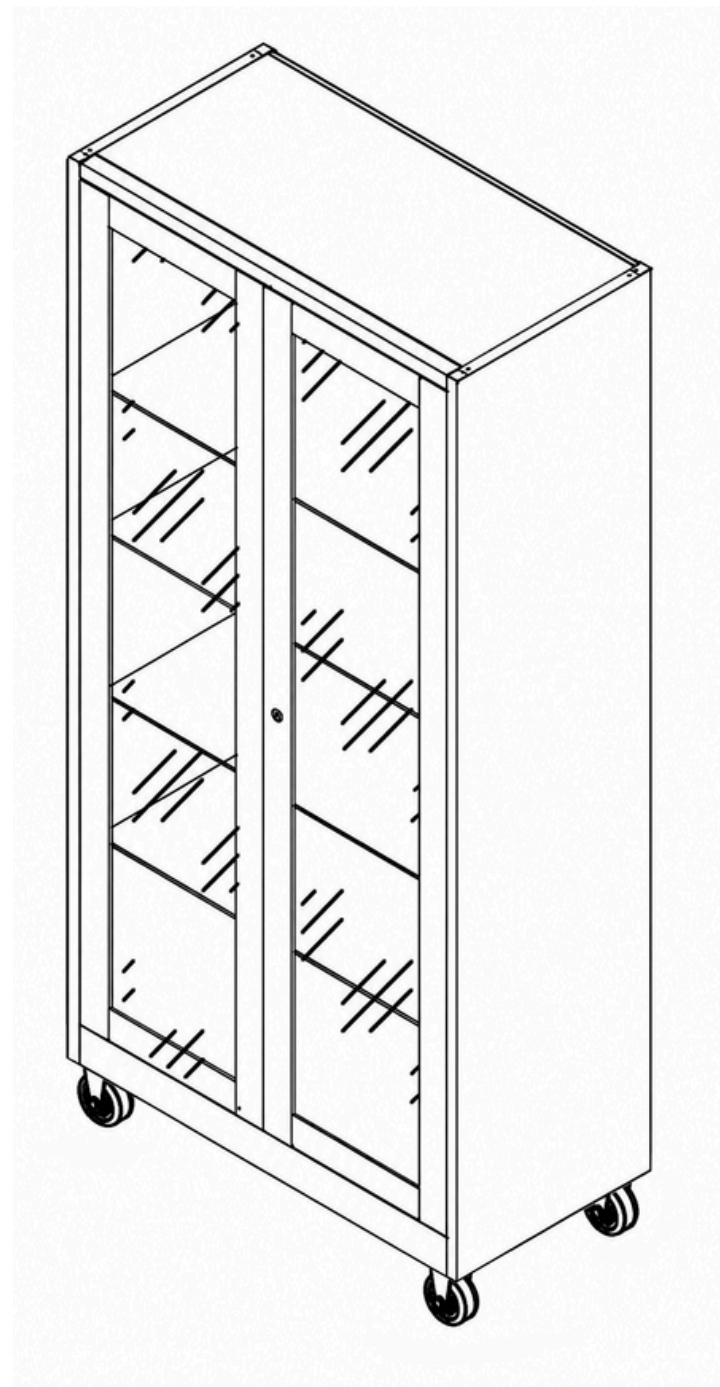



Ľavá strana: 1 ks



Pravá strana: 1 ks

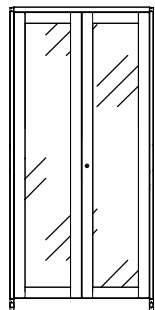

Rám dverí: 1 ks

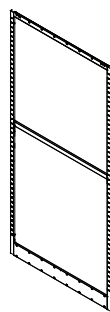

Zadná doska: 1 ks

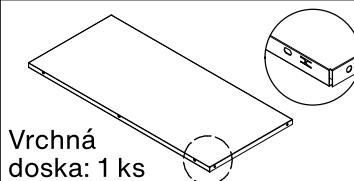

Vrchná doska: 1 ks

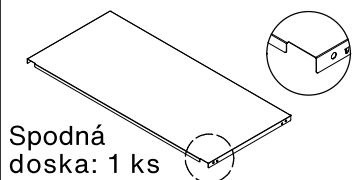

Spodná doska: 1 ks

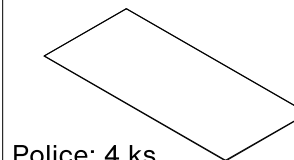

Police: 4 ks



Kolieska: 4 ks (70mm výška)

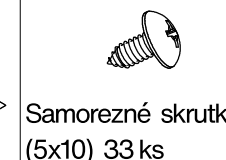

Samorezné skrutky (5x10) 33 ks



Držiak na police: 16 ks

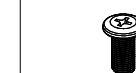

Skrutky: 16 ks (8*15)

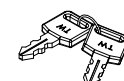

Kľúče: 1 set

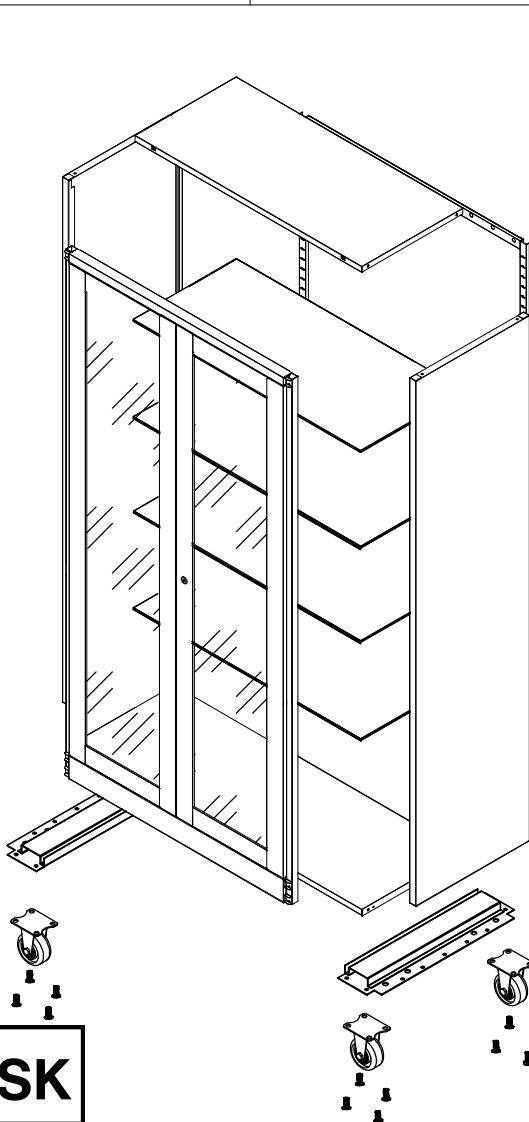

Ľavá spodná vložka: 1 ks
Pravá spodná vložka: 1 ks

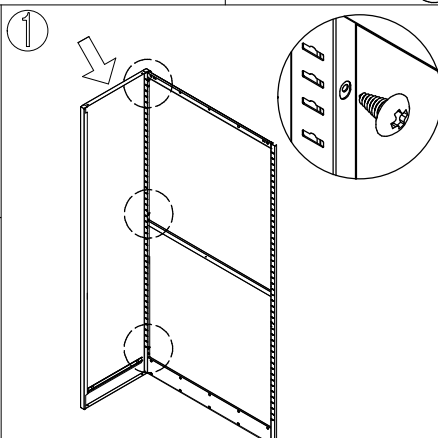

1 Priskrutkujte ľavú stranu a zadnú dosku samoreznými skrutkami (55x10)

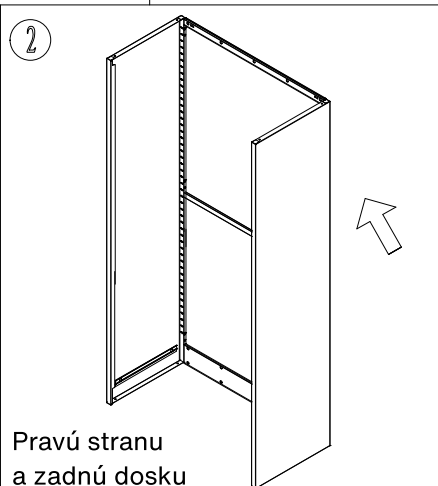

2 Pravú stranu a zadnú dosku priskrutkujte rovnakým spôsobom ako v prvom kroku

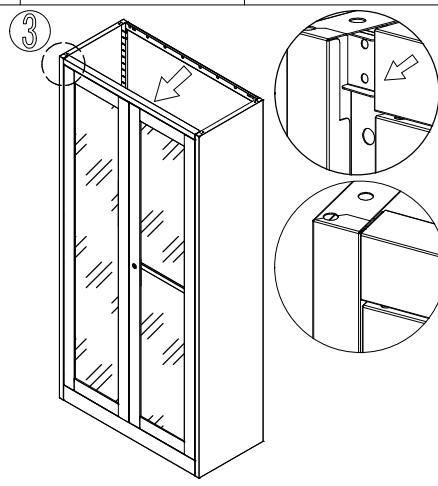

3 Upevnite zárubňu dverí do oboch bočných dosiek

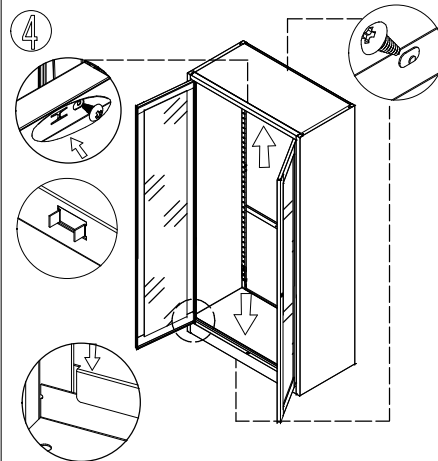

4 Nainštalujte hornú a spodnú dosku

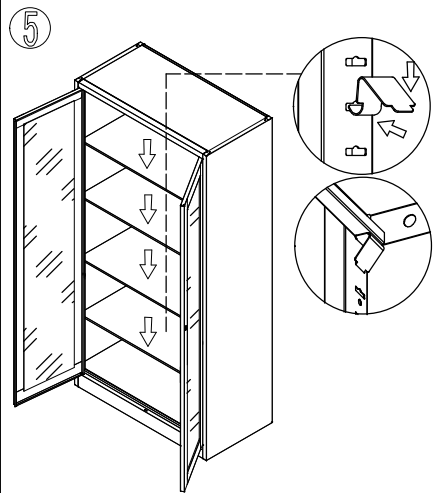

5 Nainštalujte police

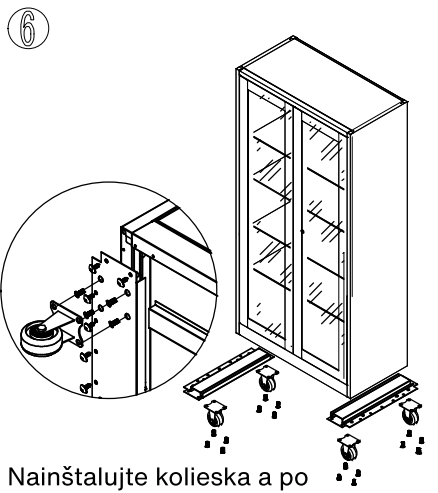

6 Nainštalujte kolieska a po inštalácii nastavte jednotlivé časti tak, aby dobre sedeli



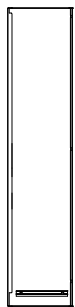

Levá strana: 1 ks



Pravá strana: 1 ks

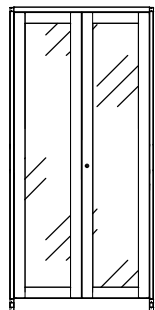

Rám dveří: 1 ks

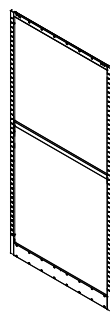

Zadní deska: 1 ks

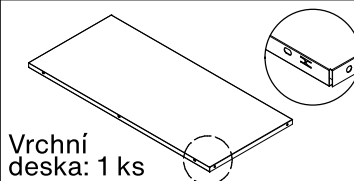

Vrchní deska: 1 ks

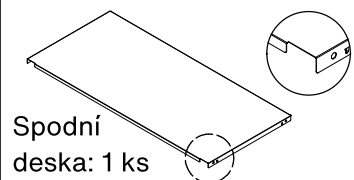

Spodní deska: 1 ks

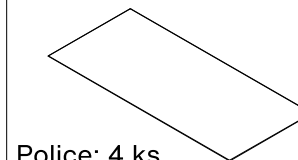

Police: 4 ks



Kolečka:
4 ks (výška 70 mm)

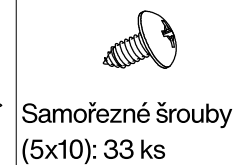

Samořezné šrouby
(5x10): 33 ks



Držák na
police: 16 ks



Šrouby:
16 ks (8x15)

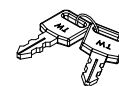

Klíče: 1 sada

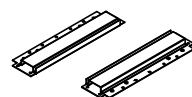
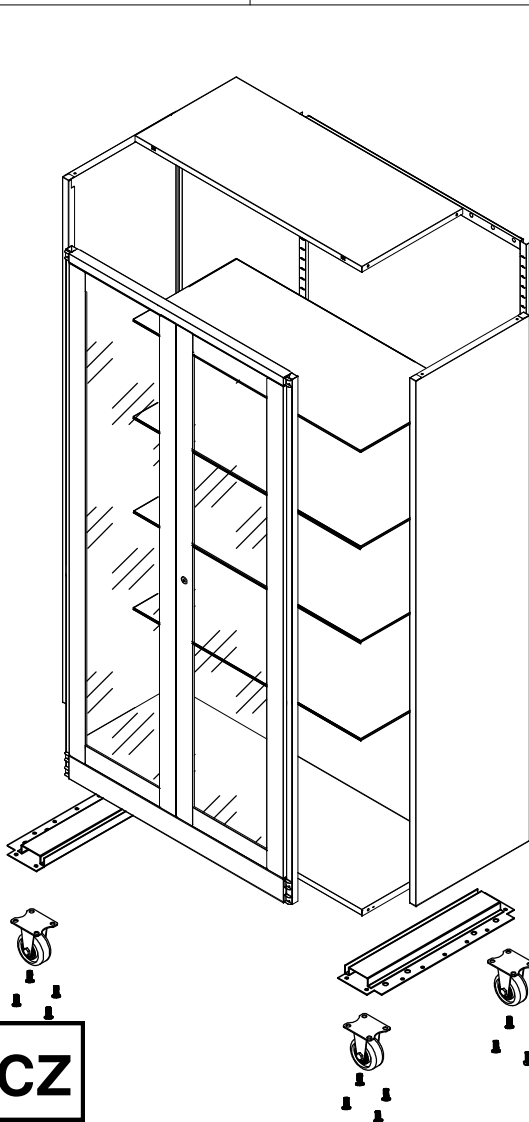

Levá spodní vložka: 1 ks
Pravá spodní vložka: 1 ks

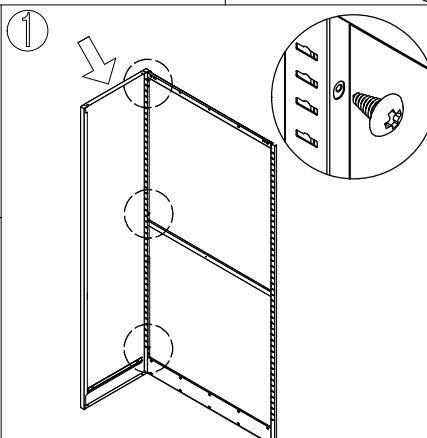

1 Přišroubujte levou stranu a zadní desku samořeznými šrouby (5x10).

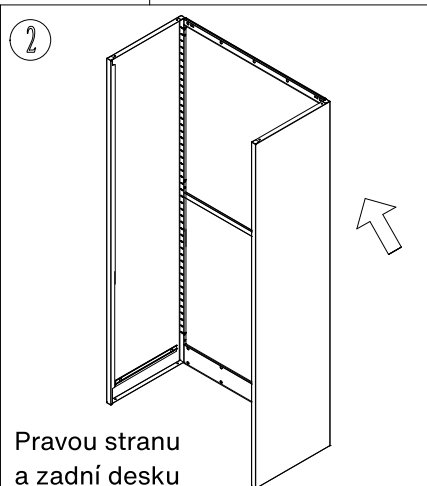

2 Pravou stranu a zadní desku přišroubujte stejným způsobem jako v prvním kroku.

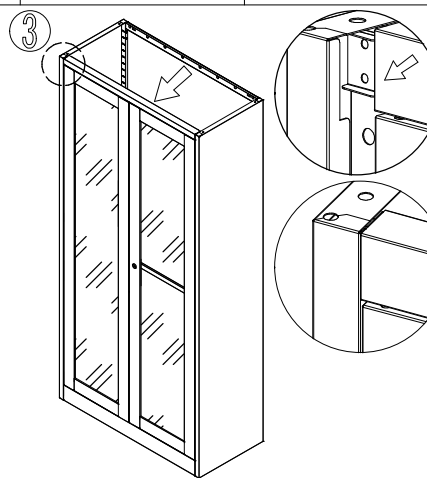

3 Upevněte zárubeň dveří do obou bočních desek.

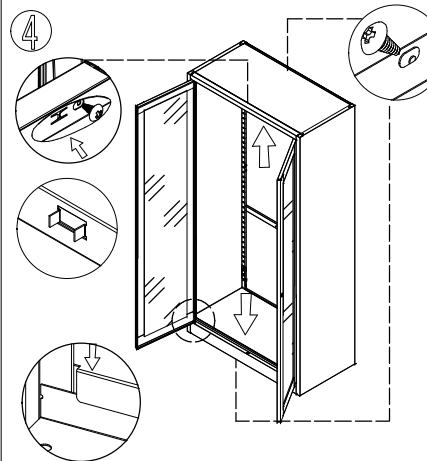

4 Nainstalujte horní a spodní desku.

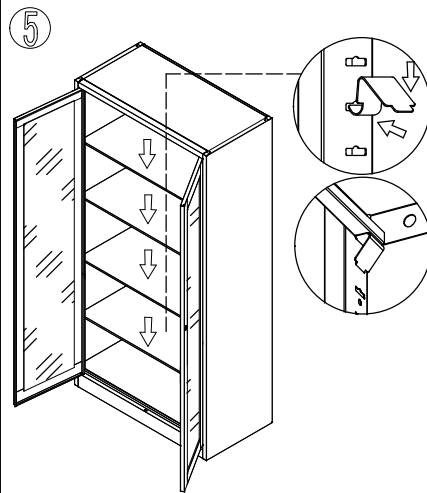

5 Nainstalujte police.

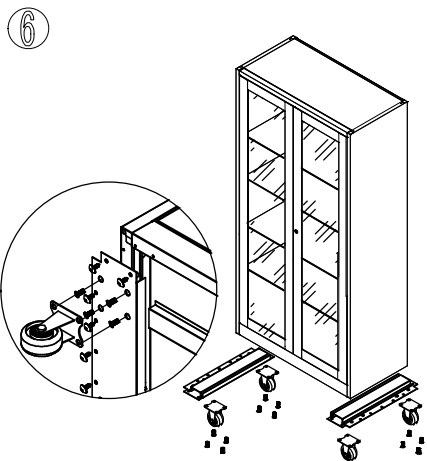

6 Nainstalujte kolečka a po instalaci nastavte jednotlivé části tak, aby dobře seděly.

CZ



Linke Seite: 1 Stk.



Rechte Seite: 1 Stk.

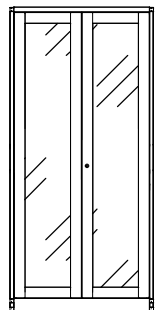

Türrahmen: 1 Stk.

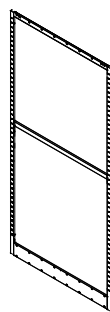

Rückwand: 1 Stk.

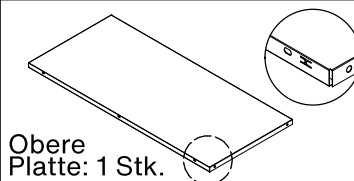

Obere Platte: 1 Stk.

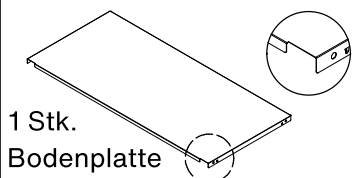

1 Stk. Bodenplatte

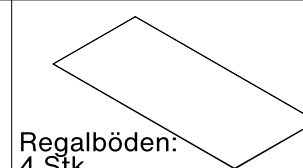

Regalböden: 4 Stk.



Rollen: 4 Stk. (70 mm Höhe)



Selbstschneidende Schrauben (5x10): 33 Stk.



Schrauben: 16 Stk. (8x15)

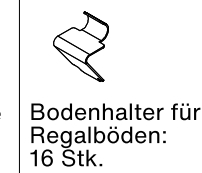

Bodenhalter für Regalböden: 16 Stk.

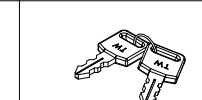

Schlüssel: 1 Set

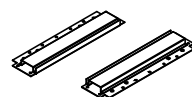
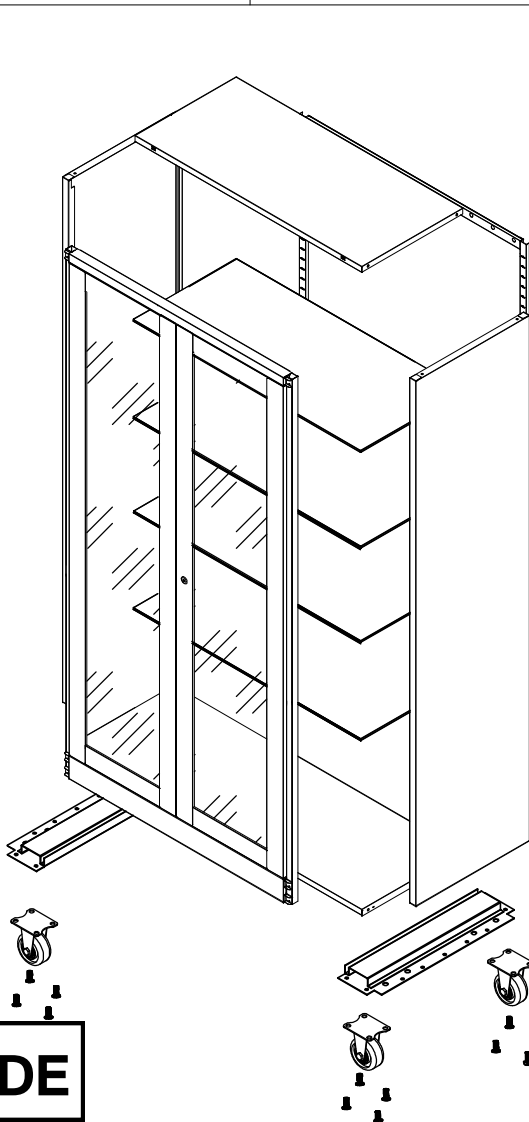

Linke untere Einlage: 1 Stk.
Rechte untere Einlage: 1 Stk.

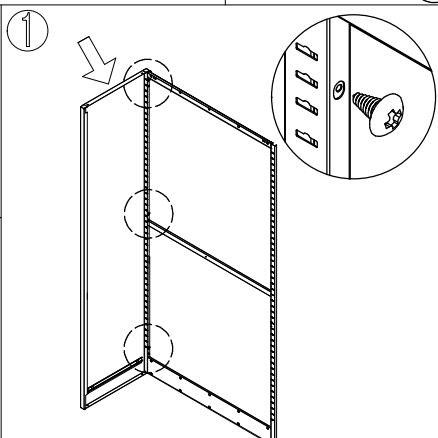

Schrauben Sie die linke Seite und die Rückwand mit selbstschneidenden Schrauben (5x10) zusammen.

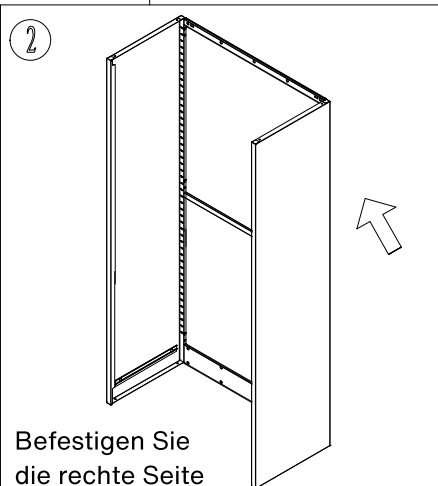

Befestigen Sie die rechte Seite und die Rückwand auf die gleiche Weise wie im ersten Schritt.

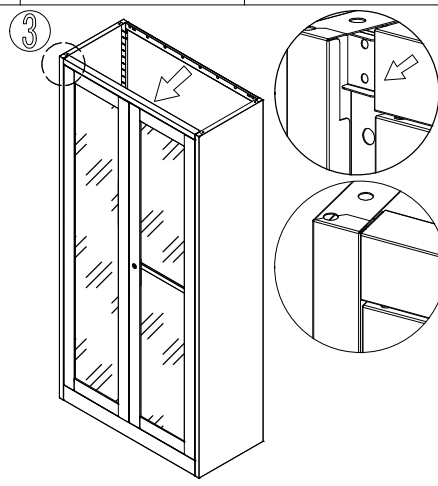

Befestigen Sie den Türrahmen an beiden Seitenplatten.

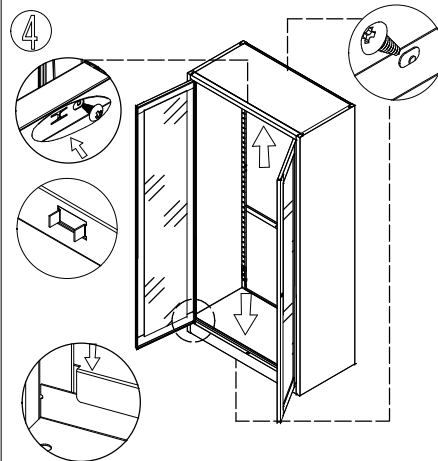

Montieren Sie die obere und untere Platte.

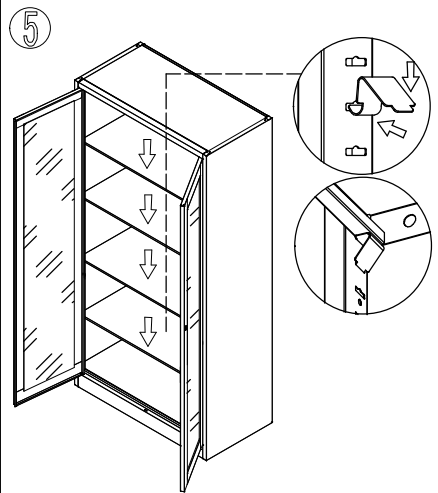

Montieren Sie die Regalböden.

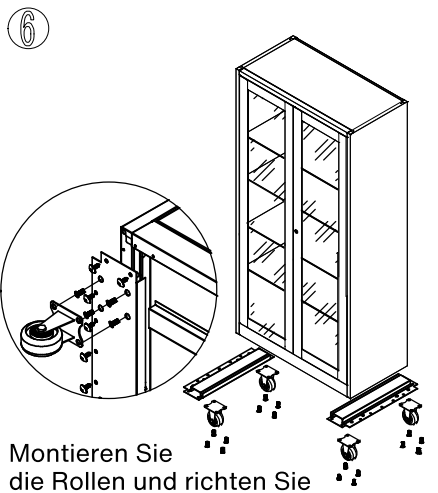

Montieren Sie die Rollen und richten Sie nach der Montage die einzelnen Teile so aus, dass sie gut sitzen.

DE

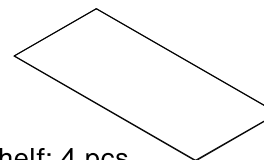
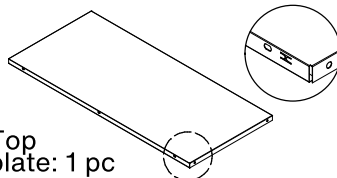
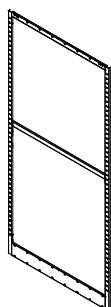
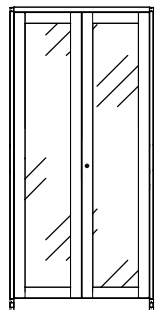

Top plate: 1 pc

Shelf: 4 pcs

Self-tapping screw (5x10): 33 pcs

Shelf holder: 16 pcs

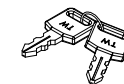
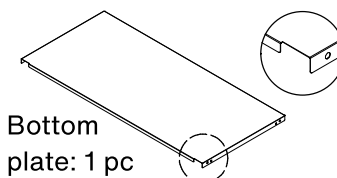

Bottom plate: 1 pc

Castor: 4 pcs (70mm height)

Screw: 16 pcs (8*15)

Key: 1 sets

Left side: 1 pc

Right side: 1 pc

Door frame: 1 pc

Back plate: 1 pc

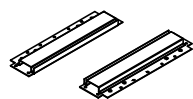
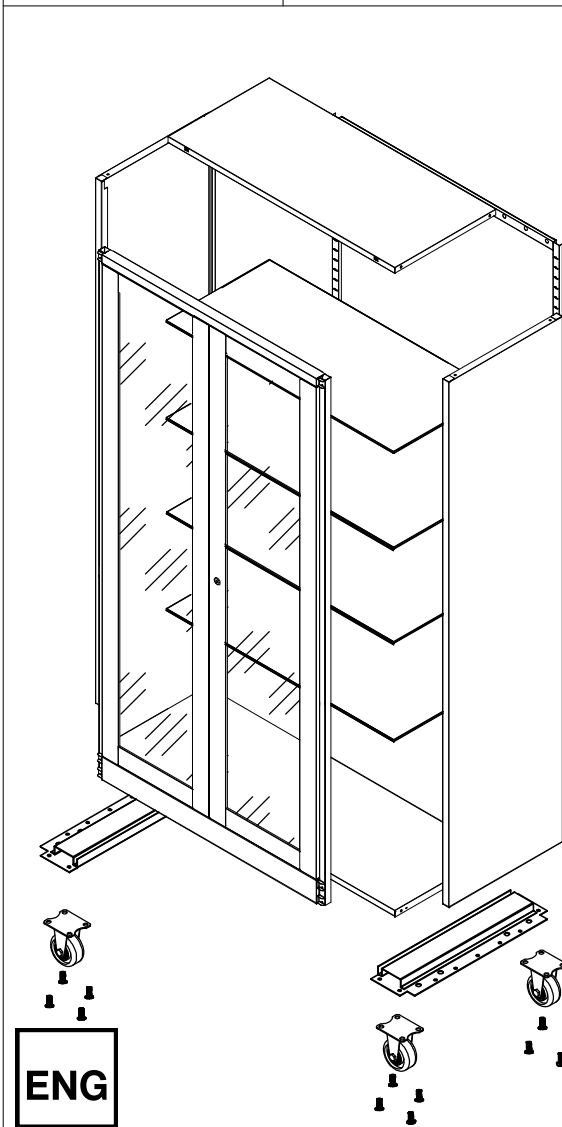

Left bottom insert: 1 pc
Right bottom insert: 1 pc

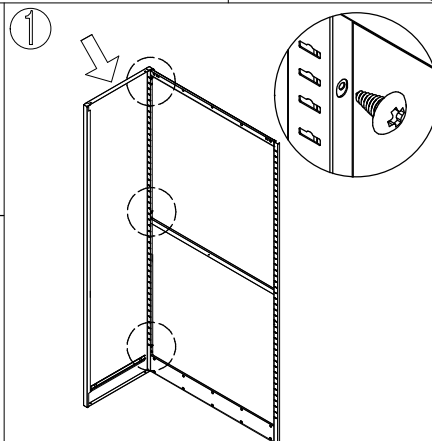

Bolt the left side and back plate with self-tapping screws (5x10).

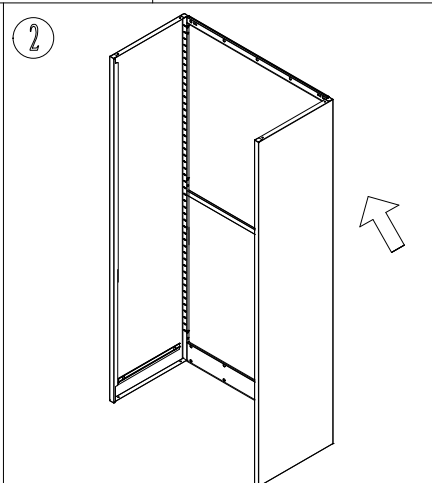

Bolt the right side and back plate in the same way as the first step.

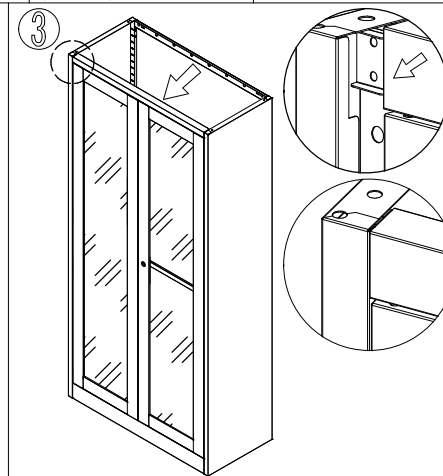

Fix the door frame onto both of the side plates.

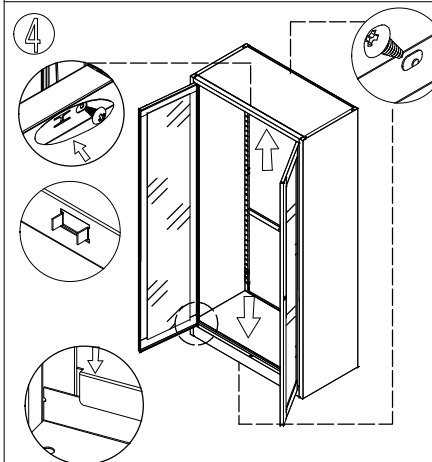

Install the top and bottom plate respectively.

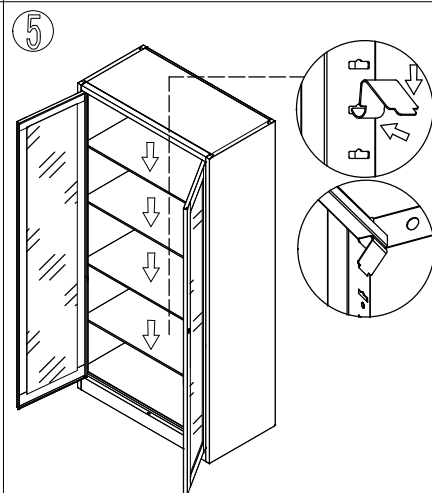

Install the shelves.

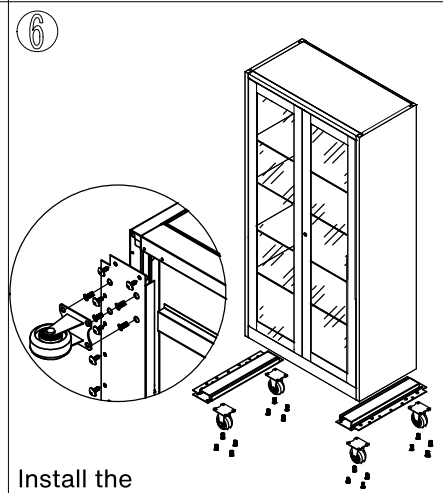

Install the castors and adjust each part till fit well after installation.

ENG



Lewa strona: 1 szt.



Prawa strona: 1 szt.

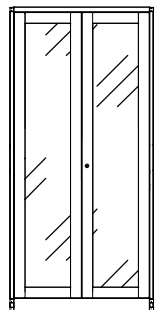

Rama drzwi: 1 szt.

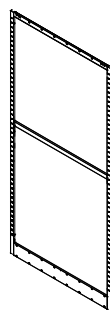

Tylna płyta: 1 szt.

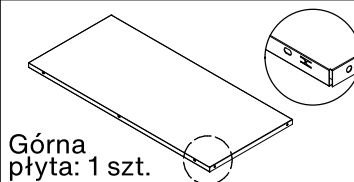

Górna płyta: 1 szt.

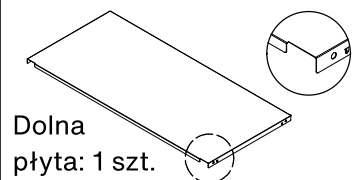

Dolna płyta: 1 szt.

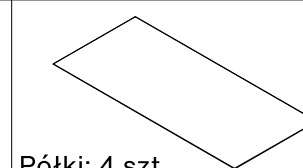

Półki: 4 szt.



Kółka:
4 szt. (wysokość 70 mm)

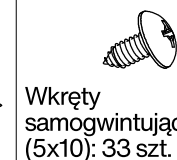

Wkręty
samogwintujące
(5x10): 33 szt.



Uchwyty do
półek: 16 szt.



Śruby:
16 szt. (8x15)

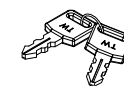

Klucze: 1 zestaw

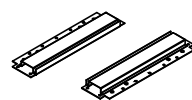
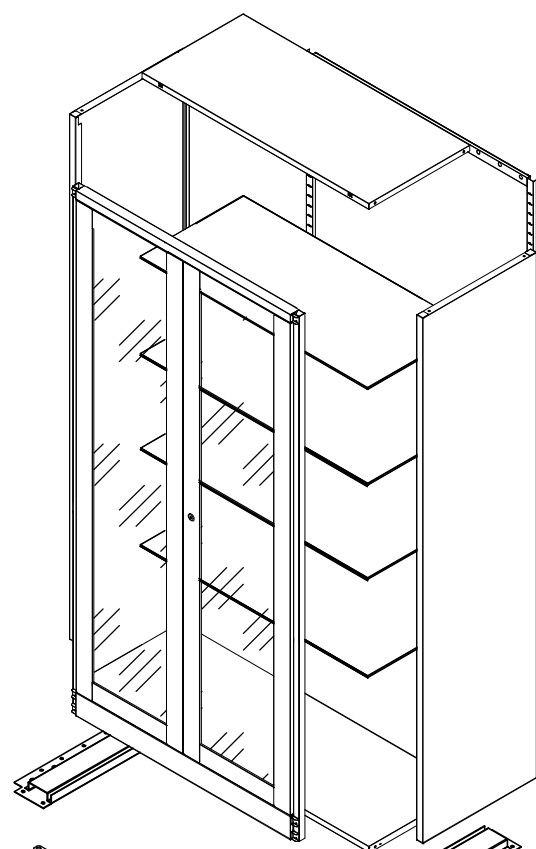

Lewa dolna wkładka: 1 szt.
Prawa dolna wkładka: 1 szt.

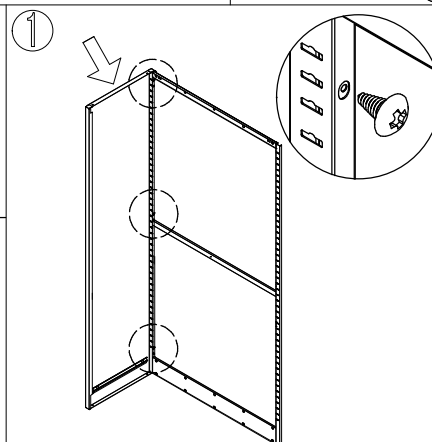

Przykręć lewą
stronę i tylną płytę za pomocą wkrętów
samogwintujących (5x10).

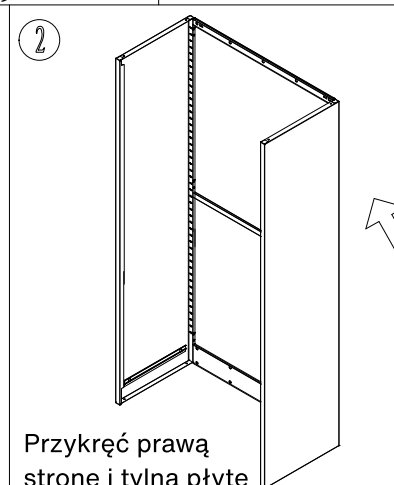

Przykręć prawą
stronę i tylną płytę
w taki sam sposób jak
w pierwszym kroku.

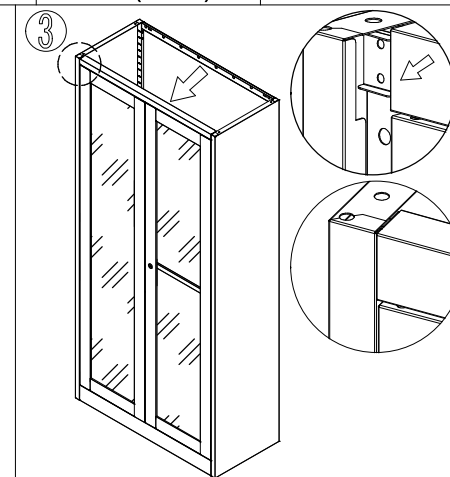

Przymocuj ościeżnicę
drzwi do obu bocznych płyt.

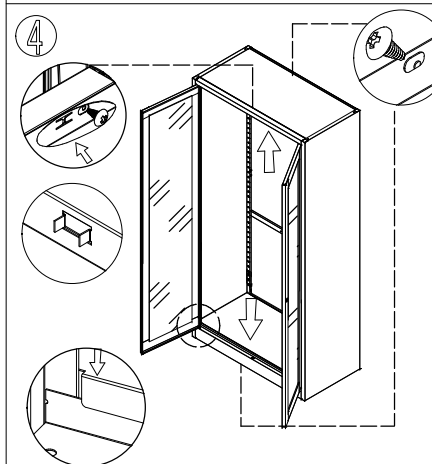

Zamontuj górną i dolną płytę.

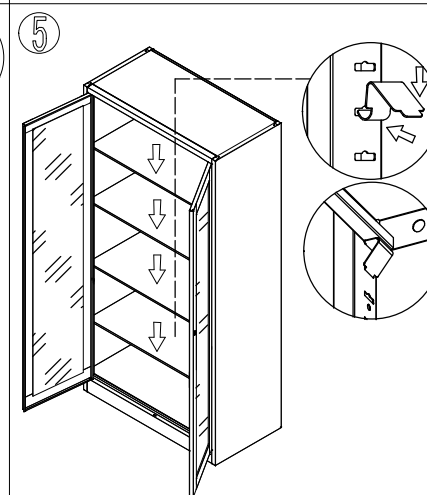

Zamontuj półki.

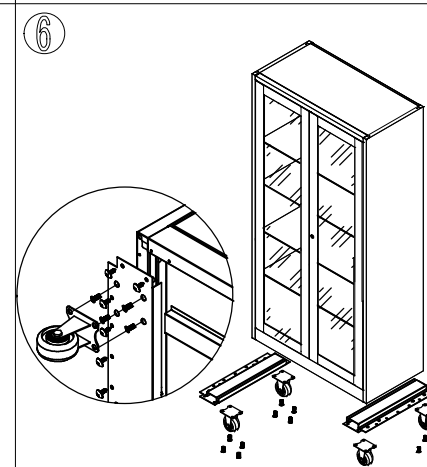

Zamontuj kółka i po
montażu wyreguluj poszczególne
części tak, aby dobrze pasowały.

PL



Partea stângă: 1 buc.



Partea dreaptă: 1 buc.

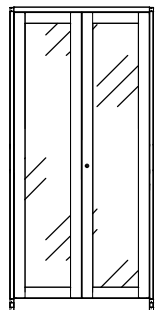

Rama ușii: 1 buc.

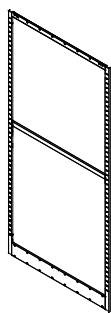

Panoul din spate: 1 buc.

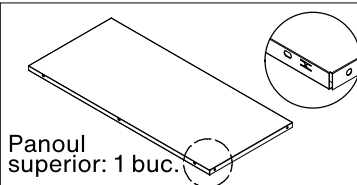

Panoul superior: 1 buc.

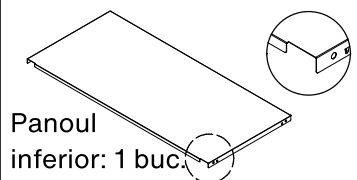

Panoul inferior: 1 buc.

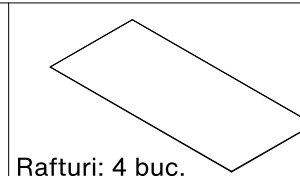

Rafturi: 4 buc.

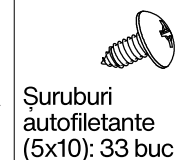

Șuruburi autofiletante (5x10): 33 buc.



Suporturi pentru rafturi: 16 buc.

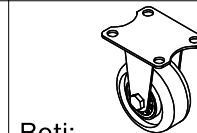

Roți: 4 buc. (înălțime 70 mm)



Șuruburi: 16 buc. (8x15)

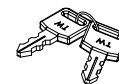

Chei: 1 set

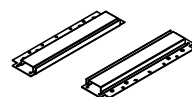
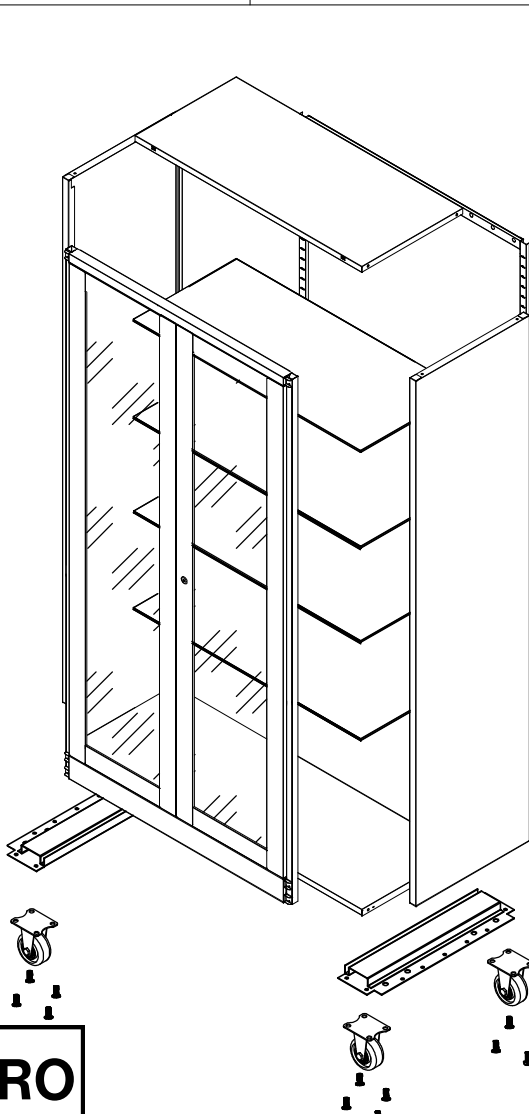

Insertie inferioară stângă: 1 buc.
Insertie inferioară dreaptă: 1 buc.

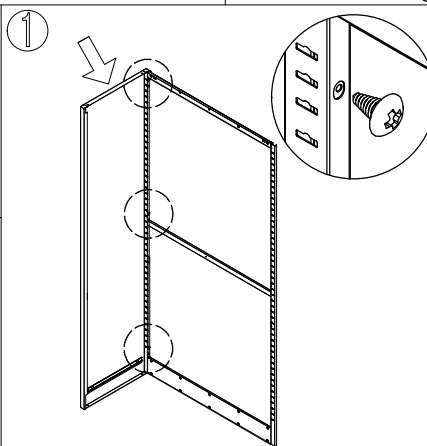

Înșurubați partea stângă și panoul din spate folosind șuruburi autofiletante (5x10).

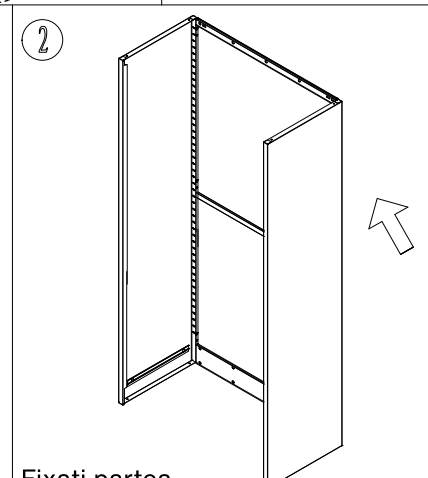

Fixați partea dreaptă și panoul din spate în același mod ca la primul pas.

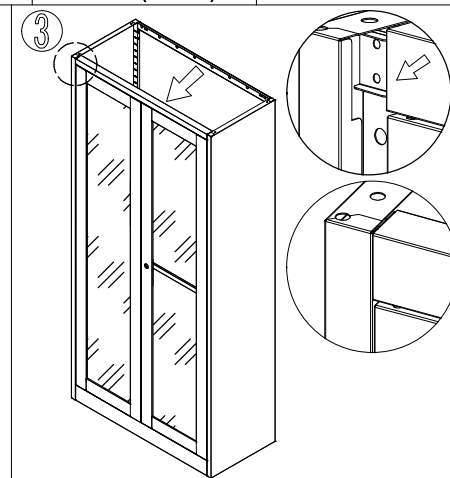

Fixați tocul ușii pe ambele panouri laterale.

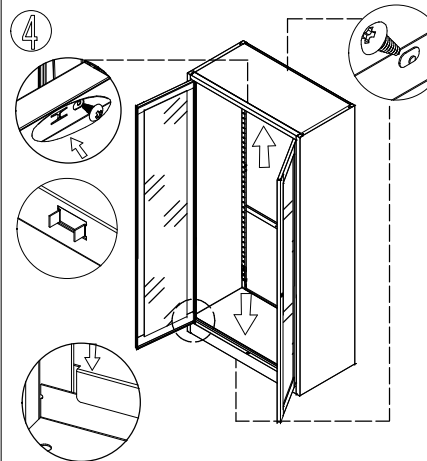

Instalați panoul superior și cel inferior.

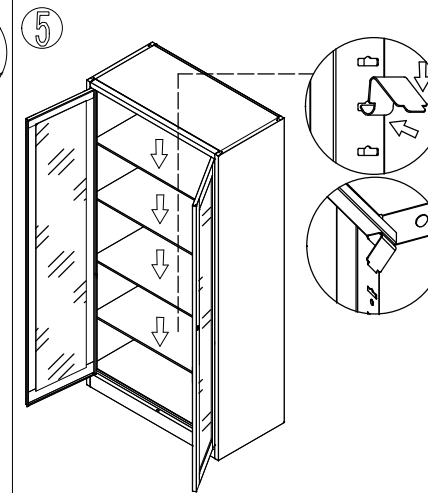

Instalați rafturile.

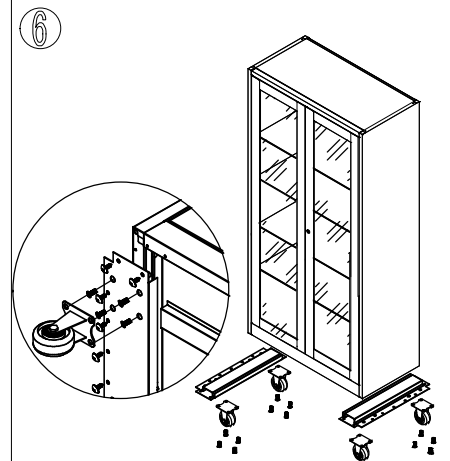

Instalați roțile și după instalare ajustați fiecare parte astfel încât să se potrivească bine.

RO



Lato sinistro: 1 pz



Lato destro: 1 pz

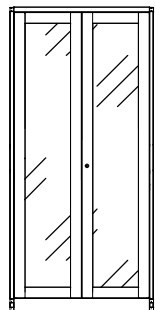

Telaio della porta: 1 pz

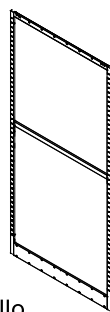

Pannello posteriore: 1 pz

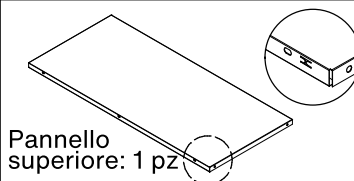

Pannello superiore: 1 pz

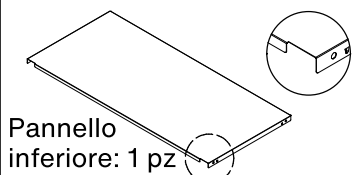

Pannello inferiore: 1 pz

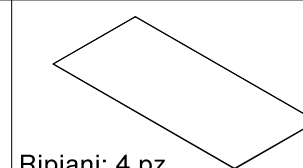

Ripiani: 4 pz



Viti autofilettanti (5x10): 33 pz



Supporti per ripiani: 16 pz



Ruote: 4 pz (altezza 70 mm)



Viti: 16 pz (8x15)

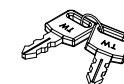

Chiavi: 1 set

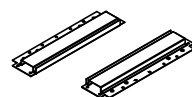
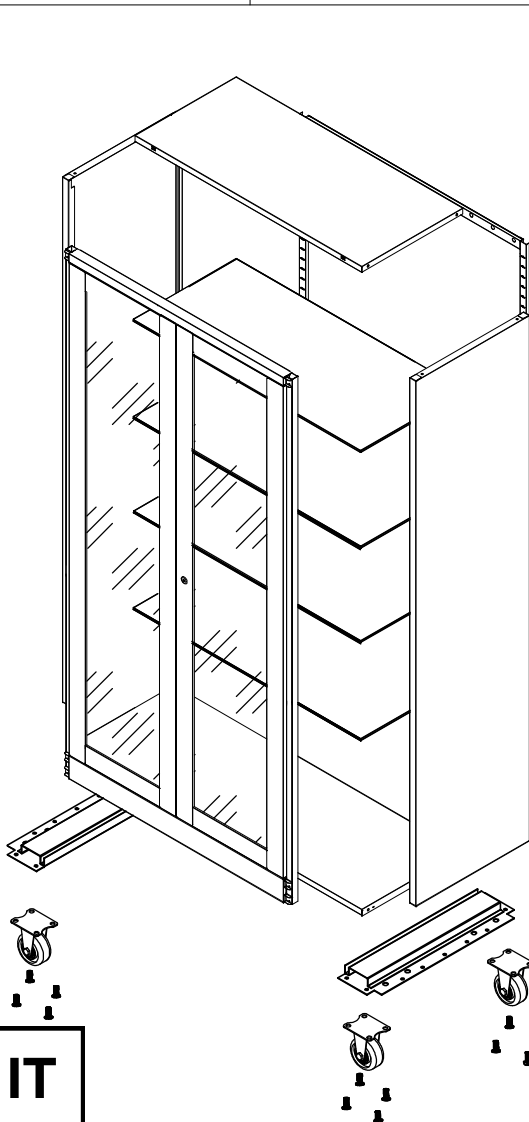

Inserto inferiore sinistro: 1 pz
Inserto inferiore destro: 1 pz

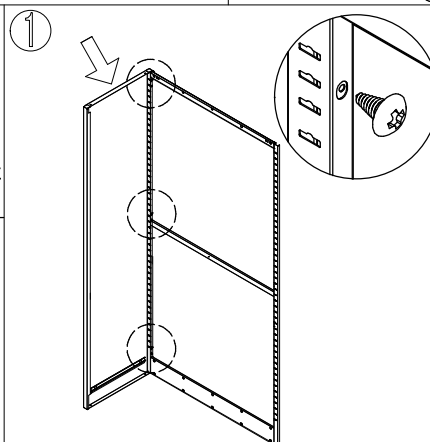

1 Avvitare il lato sinistro e il pannello posteriore utilizzando viti autofilettanti (5x10).

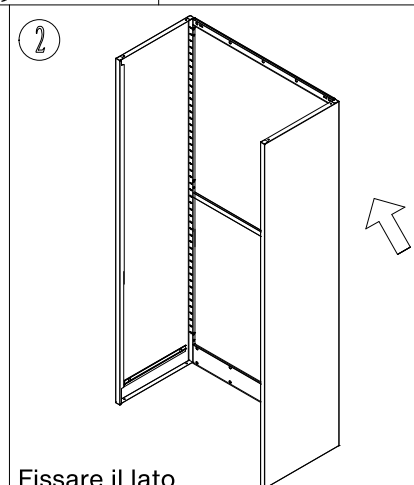

2 Fissare il lato destro e il pannello posteriore nello stesso modo del primo passaggio.

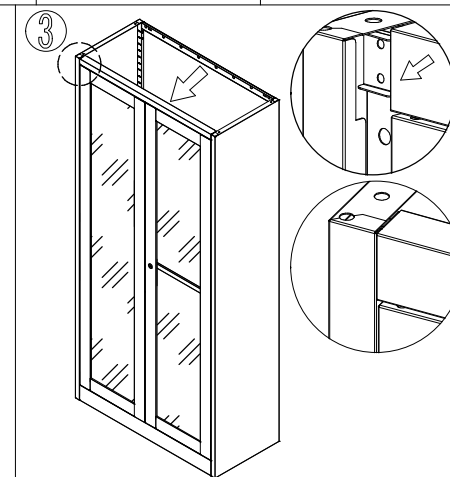

3 Fissare il telaio della porta a entrambi i pannelli laterali.

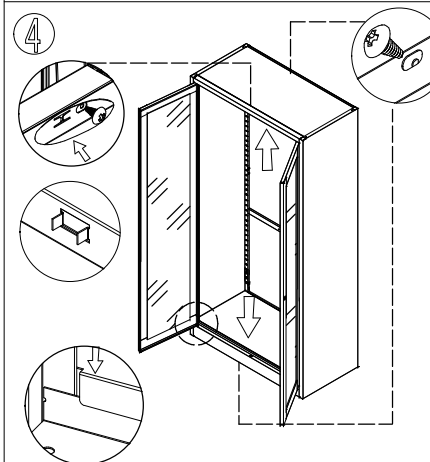

4 Installare il pannello superiore e quello inferiore.

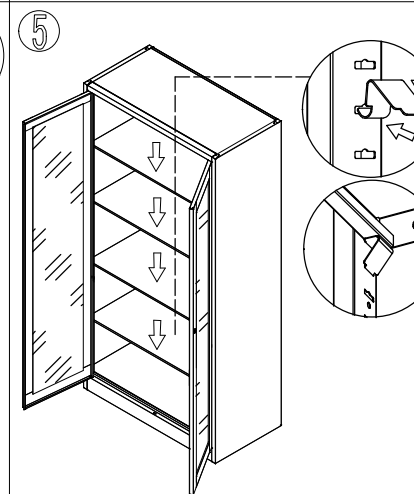

5 Installare i ripiani.

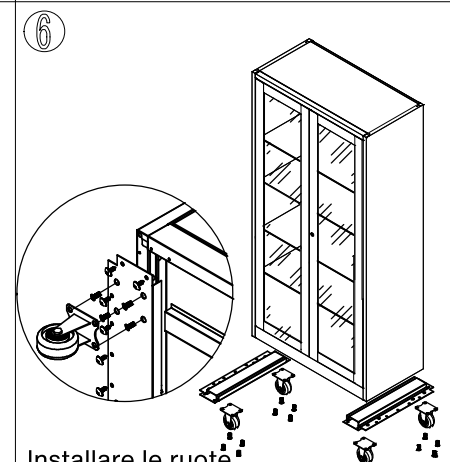

6 Installare le ruote e dopo l'installazione regolare le singole parti in modo che si adattino correttamente.

